

## Brake Winch Pacific

### Product information



The Pacific Brake Winches are compact, lightweight and a cost-effective solution for a variety of applications. They can be used for both pulling and lifting purposes. They can be supplied with a powder-coated or in stainless steel, depending on your application.

#### Features:

- Positive Weston-style brake will hold the load in any position.
- Compact, lightweight and rugged construction.
- Mechanical components enclosed for protection and safety.
- Available with a powder-coated.

**Material:** Steel

**Finish:** Powder coated

**Note:** Wire rope must be ordered separately

Part Code	Code	WLL (kg)	Max. pulling capacity kg	Cable length m	Ø wire rope mm	A mm	B mm	C mm	D mm	G mm	H mm	I mm	K mm	L mm	M mm	N mm	O mm	P mm	Q mm	R mm	S mm	T mm	U mm	W mm	Weight (kg)
501318000000660	BHW080	180	370	30	4	138	Ø10.5	40	6	12	27	39	42	138	184	86	156	273	111	155	51	Ø40	88	115	3.6
501327000000660	BHW120	270	545	23	5	138	Ø10.5	40	6	12	27	39	42	138	184	86	156	273	111	208	51	Ø48	88	115	3.7
501341000000660	BHW180	410	820	24	6	193	Ø10	70	20	29	-	65	55	193	246	108	203	284	111	319	60	Ø60	107	135	8.1
501360000000660	BHW260	600	1,200	16	8	240	Ø10	77	43	29	-	94	45	240	294	121	216	308	111	319	63	Ø75	127	162	10.3

# Blueprint

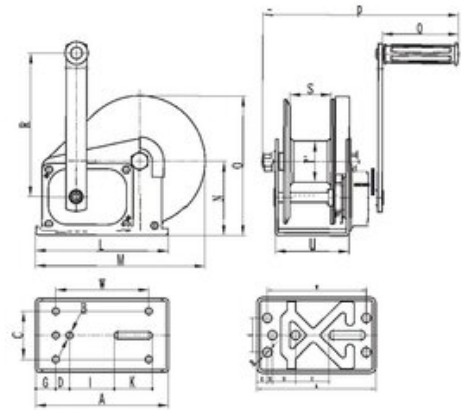

BHW180, BHW183, BHW260,  
BHW263

BHW080, BHW120, BHW123,  
BHW125N